

Hex Cap Screw, DIN 933 Fully Threaded

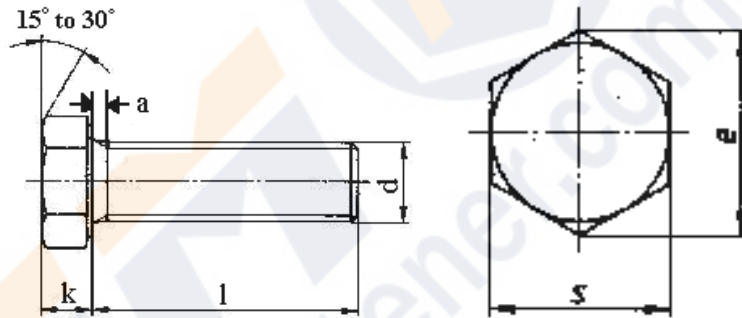

Nominal Size	e		s			K					a
	Width Across Corners		Width Across Flats			Head Height					
	Min.		Max.	Min.		Grade A			Grade B		
	Grade A	Grade B	Nom.	Grade A	Grade B	Nom.	Min.	Max.	Min.	Max.	
3	6.01	-	5.5	5.32	-	2	1.88	2.12	-	-	1.50
4	7.66	-	7	6.78	-	2.8	2.68	2.92	-	-	2.10
5	8.79	-	8	7.78	-	3.5	3.35	3.65	-	-	2.40
6	11.05	-	10	9.78	-	4	3.85	4.15	-	-	3.00
7	12.12	-	11	10.73	-	4.8	4.65	4.95	-	-	3.00
8	14.38	-	13	12.73	-	5.3	5.15	5.45	-	-	3.75
10	18.9	-	17	16.73	-	6.4	6.22	6.58	-	-	4.50
12	21.1	-	19	18.67	-	7.5	7.32	7.68	-	-	5.25
14	24.49	-	22	21.67	-	8.8	8.62	8.98	-	-	6.00
16	26.75	26.17	24	23.67	23.16	10	9.82	10.18	9.71	10.29	6.00
18	30.14	29.56	27	26.67	26.16	11.5	11.28	11.72	11.15	11.85	7.50
20	33.53	32.95	30	29.67	29.16	12.5	12.28	12.72	12.15	12.85	7.50
22	35.72	35.03	32	31.61	31	14	13.78	14.22	13.65	14.35	7.50
24	39.98	39.55	36	35.38	35	15	14.78	15.22	14.65	15.35	9.00
27	-	45.2	41	-	40	17	-	-	16.65	17.35	9.00
30	-	50.85	46	-	45	18.7	-	-	18.28	19.12	10.50
33	-	55.37	50	-	49	21	-	-	20.58	21.42	10.50
36	-	60.79	55	-	53.8	22.5	-	-	22.08	22.92	12.00
39	-	66.44	60	-	58.8	25	-	-	24.58	25.42	12.00
42	-	71.3	65	-	63.1	26	-	-	25.58	26.42	13.50
48	-	82.6	75	-	73.1	30	-	-	29.58	30.42	15.00

Specification Requirements:

- Dimensions: DIN 933.
- Threads: 6g
- Material & Mechanical Properties: ISO 898