

## Carriage Bolt, Metric, DIN 603

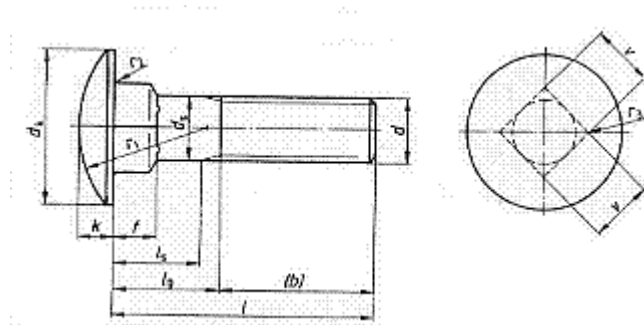

Size	Pitch	dk		ds		f		k		r1	r2	r3	v	
		Min.	Max.	Min.	Max.	Min.	Max.	Min.	Max.				Min.	Max.
M6	1	15.45	16.55	5.52	6	3.4	4.6	3.12	3.89	12.6	0.5	0.9	5.52	6.48
M8	1.25	19.35	20.65	7.42	8	4.4	5.6	4.12	4.98	16	0.5	1.2	7.42	8.58
M10	1.5	23.35	24.65	9.42	10	5.4	6.6	4.62	5.38	19.2	0.5	1.5	9.42	10.58
M12	1.75	29.35	30.65	11.3	12	7.25	8.75	6.05	6.95	24.1	1	1.8	11.3	12.7
M16	2	37.2	38.8	15.3	16	11.1	12.9	8.05	8.95	29.3	1	2.4	15.3	16.7

### Specification Requirements:

- Dimensions: DIN 603
- Threads: 8g
- Material & Mechanical Properties: ISC 80%
- Head Marking: Property Class and Manufacturer's ID